

Sample Questions

for

ASAT

(ALLEN Scholarship Cum Admission Test)

CLASSROOM CONTACT PROGRAMME

PRE-NURTURE & CAREER FOUNDATION : CLASS-X

(FOR IX to X MOVING STUDENTS)



Corporate Office

ALLEN CAREER INSTITUTE

"SANKALP", CP-6, Indra Vihar, Kota (Rajasthan)-324005

☎ +91-744-2757575 ✉ info@allen.ac.in

www.allen.ac.in

INSTRUCTIONS

Things NOT ALLOWED in EXAM HALL : Blank Paper, clipboard, log table, slide rule, calculator, camera, mobile and any electronic or electrical gadget. If you are carrying any of these then keep them at a place specified by invigilator at your own risk

1. This booklet is your Question Paper. **DO NOT** break seal of Booklet until the invigilator instructs to do so.
2. Fill your Form No. in the space provided on the top of this page.
3. The Answer Sheet is provided to you separately which is a machine readable Optical Response Sheet (ORS). You have to mark your answers in the ORS by darkening bubble, as per your answer choice, by using black & blue ball point pen.
4. Total Questions to be Attempted 80. Part-I : 20 Questions & Part-II : 60 Questions.
5. After breaking the Question Paper seal, check the following:
 - a. There are **14 pages** in the booklet containing question no. 1 to 80 under 2 Parts i.e. Part-I & Part-II.
 - b. Part-I contains total 20 questions of IQ (Mental Ability).
 - c. Part-II contains total 60 questions under 4 sections which are - Section (A) : Physics, Section (B) : Chemistry, Section(C) : Biology & Section (D): Mathematics.
6. Marking Scheme:
 - a. If darkened bubble is RIGHT answer : **4 Marks**.
 - b. If no bubble is darkened in any question: **No Mark**.
 - c. **Only for part - II** : If darkened bubble is WRONG answer: **-1 Mark (Minus One Mark)**.
7. Think wisely before darkening bubble as there is negative marking for wrong answer.
8. If you are found involved in cheating or disturbing others then your ORS will be cancelled.
9. Do not put any stain on ORS and hand it over back properly to the invigilator.

PART-I
IQ (MENTAL ABILITY)

This section contains **20 Multiple Choice Questions**. Each question has four choices (1), (2), (3) and (4) out of which **ONLY ONE** is correct.

1. Each question consists of five statements followed by options consisting of three statements put together in a specific order. Choose the option which indicates a valid argument, that is where the third statement is a conclusion drawn from the preceding two statements.

- A. Apples are not sweets.
 B. Some apples are sweets.
 C. All sweets are tasty.
 D. Some apples are not tasty.
 E. No apple is tasty.

- (1) CEA (2) BDC (3) CBD (4) EAC

2. How many triangles are there in the following figure ?

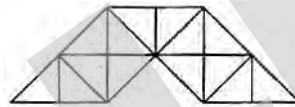

- (1) 25 (2) 20 (3) 31 (4) 29

Directions (Q.3 & Q.4) : In a school, there were five teachers. A and B were teaching Hindi and English. C and B were teaching English and Geography. D and A were teaching Mathematics and Hindi. E and B were teaching History and French.

3. Who among the teachers was teaching maximum number of subjects ?

- (1) A (2) B (3) C (4) D

4. D, B and A were teaching which of the following subjects ?

- (1) English only (2) Hindi and English
 (3) English and Geography (4) Hindi only

5. How many 7s immediately preceded by 6 but not immediately followed by 4 are there in the following series?

7 4 2 7 6 4 3 6 7 5 3 5 7 8 4 3 7 6 7 2 4 0 6 7 4 3

- (1) One (2) Two (3) Four (4) Six

6. Find the next term in the series : 10, 19, 40, 77, 158, ?

- (1) 311 (2) 307 (3) 301 (4) 299

7. When the time by the watch is 20 minutes past 7, the angle between the hands of the watch is
 (1) 100° (2) 90° (3) 80° (4) 95°
8. If 12th March 1986 was Wednesday, then 31st March 1994 would be
 (1) Wednesday (2) Thursday
 (3) Friday (4) Saturday
9. Of the following figures, which figure does not belong to the cube ?

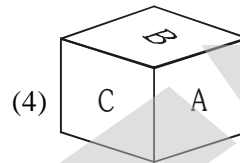
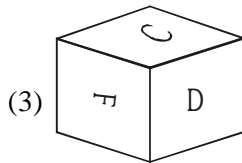
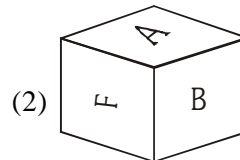
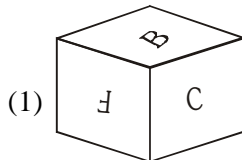

10. Find the missing term in the following Figure

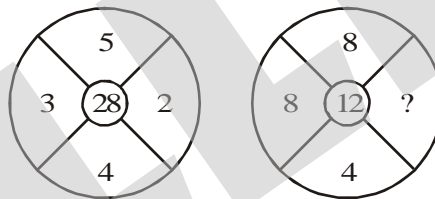

- (1) 3 (2) 9 (3) 1 (4) 2

Direction (Q.11 & Q.12) : Read the following information carefully and answer the questions given below it

- (i) P, Q, R, S, T and U are six members in a family in which there are two married couples.
- (ii) T, a teacher is married to the doctor who is mother of R and U.
- (iii) Q, the lawyer is married to P.
- (iv) P has one son and one grandson.
- (v) Of the two married ladies one is a housewife.
- (vi) There is also one student and male engineer in the family.

11. How is P related to R ?
 (1) Grandfather (2) Mother
 (3) Sister (4) Grandmother
12. How is R related to U ?
 (1) Brother (2) Sister
 (3) Brother or Sister (4) Data inadequate

13. $P \neq Q$ implies that Q is standing 2 km to the right of P

$P * Q$ implies that Q is standing 2 km to the left of P

$P @ Q$ implies that Q is standing 2 km below P

If $F \neq S @ B * V$, in which direction is F with respect to V?

- (1) North (2) South
 (3) East (4) West

14. In the figure, number in any cell is obtained by adding two numbers in the cells directly below it.

The value of X-Y is

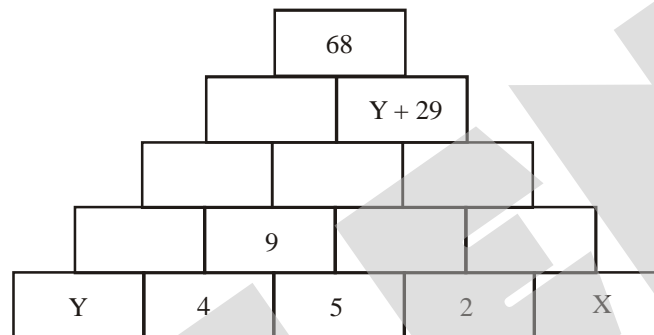

- (1) 2 (2) 3
 (3) 4 (4) 5

15. In a game "Pass the ball" position of some players are as follows

'A' is 20 meters to the north of 'B' who is 18 meters to the east of 'C'. If the ball was initially with B and is passed to C, in which direction A is to C ?

- (1) North-East (2) North-West
 (3) South-East (4) None of these

16. What is the number of routes from P to Q?

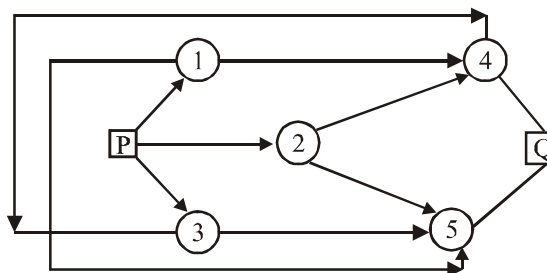

- (1) 5 (2) 6 (3) 9 (4) 1

17. In the following question below three statements (I, II, III) are given followed by four conclusions. You have to take the given statements to be true even if they seem to be at variance with commonly known facts. Read all the conclusions and then decide which of the given conclusions logically follows from the given statements, disregarding commonly known facts. Choose the correct options.

Statements : (I) Some drivers are technicians.

(II) All technicians are engineers.

(III) Some engineers are lecturers.

Conclusions : (A) Some technicians are lecturers.

(B) Some lecturers are drivers.

(C) All engineers are technicians.

(D) Some engineers are drivers.

(1) Only C follows

(2) Only D follows

(3) Only C and D follows

(4) None of these

18. Symbols are to be coded as follows in a language :

Symbol : @ \$ # * % £ + X = ?

Code : F R H S E A D N O K

Following conditions are observed here :

(i) If the middle symbol is £ then it is to be coded as L

(ii) If the first symbol is + and the last symbol is # both are to be coded as 6

(iii) If the first symbol is % and the last symbol is \$ then both are to be coded as 4

(iv) If the first and last symbol are @ then both are to be coded as 2

Applying these conditions, find out the correct code for the symbols in the question given below.

% @ = £ + *\$

(1) 4 F O L D S 4

(2) E F O L D S R

(3) 4 F O A D S 4

(4) E F O L D S 6

19. 343 cubes of similar size are arranged in the form of a bigger cube (7 cubes on each side, i.e. $7 \times 7 \times 7$) and kept at the corner of a room, all the exposed surfaces are painted then How many of the cubes have at least 2 faces painted ?

(1) 19

(2) 144

(3) 120

(4) None of these

20. In the following question, choose the alternative figure in which the question figure (X) is embedded.



(X)

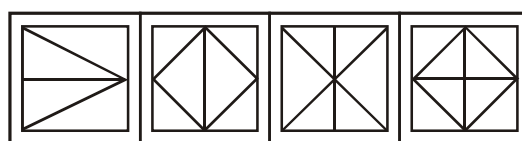

(1)

(2)

(3)

(4)

PART-II

SECTION-A : PHYSICS

This section contains **15 Multiple Choice Questions**. Each question has four choices (1), (2), (3) and (4) out of which **ONLY ONE** is correct.

21. The figure represents the velocity-time graph of body moving in a straight line. How much distance does it travel during the last 10 seconds?

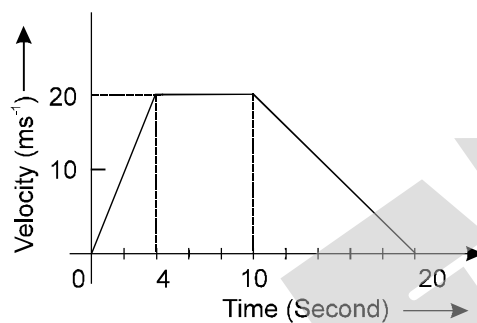

- (1) 40 m (2) 80 m (3) 100 m (4) 220 m
22. A force of 15 N gives a mass m_1 an acceleration of 3 m/sec^2 and mass m_2 an acceleration of 5 m/sec^2 . What acceleration would it give if both the masses were tied together ?
- (1) 3 m/sec^2 (2) 5 m/sec^2 (3) 4 m/sec^2 (4) None of these
23. The value of universal gravitational constant
- (1) Changes with change of place (2) Does not change from place to place
- (3) Becomes more at night (4) Becomes more during the day
24. An athlete runs over a certain distance before taking a long jump, because due to this
- (1) his mass gets decreased, so he can jump over a long distance
- (2) he gains inertia of motion, so he can take a longer jump
- (3) he gets the power of God, so he can take a longer jump
- (4) he follows law of conservation of kinetic energy
25. The position of an object in equal time intervals is shown in figure.



Which graph below correctly represents position versus time for this object ?

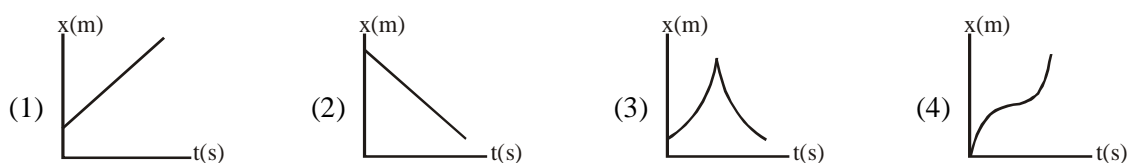

26. What is the velocity of a body of mass 100 g having K.E. of 20 J ?
 (1) 2 m/s (2) 20 m/s (3) 40 m/s (4) None of these
27. As the frequency of a source decreases in a given medium, the wavelength of a periodic longitudinal wave
 (1) increases, but the speed of the wave remains constant.
 (2) increases, and the speed of the wave increases.
 (3) decreases, but the speed of the wave remains constant.
 (4) decreases, and the speed of the wave decreases.
28. What will be the value of acceleration due to gravity at a height 2R from the surface of earth ?
 (1) 1.1 m/s² (2) 2.2 m/s²
 (3) 3.3 m/s² (4) 4.9 m/s²
29. Mark the incorrect statement.

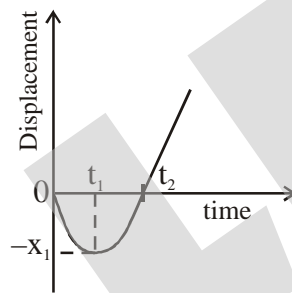

- (1) From time $t = 0$ to $t = t_1$, speed of the particle is decreasing
 (2) From $t = t_1$ to $t = t_2$, speed of the particle is increasing
 (3) Velocity of the particle from $t = 0$ to $t = t_1$ is negative
 (4) At $t = t_1$, velocity of the particle is maximum
30. In the table below, which planetary system has the greatest gravitational force acting between the planet and its moon?

Mass and Distance Data for Planets and Their Moons			
Planetary System	Planet mass (in kg)	Moon mass (in kg)	Distance from planet (in km)
1	600×10^{22}	6×10^{22}	2×10^6
2	600×10^{22}	6×10^{22}	3×10^6
3	600×10^{22}	12×10^{22}	2×10^6
4	600×10^{22}	12×10^{22}	1×10^6

- (1) 1 (2) 2 (3) 3 (4) 4

Comprehension for (Q.No.31 to Q.No.33)

Two forces $f_1 = 20\text{ N}$ & $f_2 = 30\text{ N}$ are acting on an object as shown in fig.

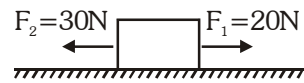

31. The net force acting on an object is
 (1) 30 N (2) 20 N (3) 50 N (4) 10 N
32. The direction of the net force acting on an object is
 (1) In the direction of F_1 (2) In the direction of F_2
 (3) Upward (4) Downward
33. The extra force acting on an object if it is not moving here should be
 (1) 20 N (2) 30 N (3) 10 N (4) 0 N

Comprehension for (Q.No.34 to Q.No.35)

An object may store energy by virtue of its position. The energy that is stored and held in readiness is called potential energy (PE) because in the stored state it has the potential for doing work. A stretched or compressed spring, for example, has the potential for doing work. A stretched or compressed spring, for example, has the potential for doing work. When a bow is drawn, energy is stored in the bow. The bow can do work on the arrow. A stretched rubber band has potential energy because of the relative position of its parts. If the rubber band is part of a slingshot, it is capable of doing work.

The amount of gravitational potential energy possessed by an elevated object is equal to the work done against gravity in lifting it. The work done equals the force required to move it upward times the vertical distance it is moved (remember $W = Fd$). The upward force required while moving at constant velocity is equal to the weight, mg , of the object, so the work done in lifting it through a height h is the product mgh .

34. How much work is done in lifting the 100-N ball a vertical distance of 2 m?

- (1) 100 J
 (2) 200 J
 (3) 300 J
 (4) 400 J

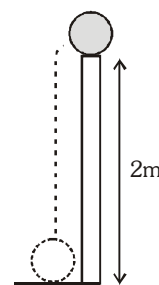

35. How much work is done in pushing the same ball up the 4 m long ramp?

- (1) 100 J
 (2) 200 J
 (3) 300 J
 (4) 400 J

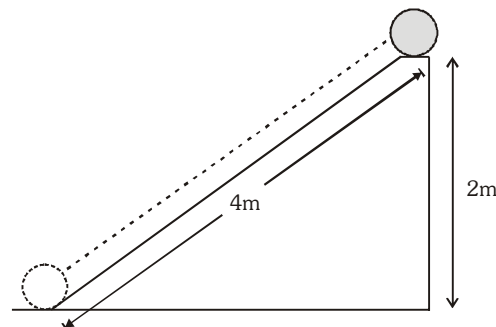

SECTION-B : CHEMISTRY

This section contains **15 Multiple Choice Questions**. Each question has four choices (1), (2), (3) and (4) out of which **ONLY ONE** is correct.

36. An element "X" after reacting with acids liberate hydrogen gas and can displace Lead and Tin from their salt solution. The metal 'X' is :
- (1) Copper (2) Gold
 (3) Nickel (4) Mercury
37. Match Column-I with Column-II and select the correct answer using the code given below the columns.

	Column-I		Column-II
(A)	Hardest Non-metal	(p)	Graphite
(B)	Non-metal conducts electricity	(q)	Sulphur
(C)	Non-metal with lustre	(r)	Diamond (Carbon)
(D)	Non-metal used as fungicide	(s)	Iodine

- (1) A → (r); B → (p); C → (s); D → (q) (2) A → (q); B → (p); C → (s); D → (r)
 (3) A → (p); B → (r); C → (s); D → (q) (4) A → (r); B → (p); C → (q); D → (s)
38. At heights if water boils at 70°C, then the cooking of pulse requires
- (1) More time and more heat (2) Less time and more heat
 (3) Less time and less heat (4) More time and less heat
39. Benzene and water can be separated by
- (1) Separating funnel (2) Sublimation
 (3) Filtration (4) None of these
40. In presence of water, ignition temperature of paper
- (1) Decreases (2) Increases
 (3) Remains constant (4) Can decrease or increase
41. Study the following equations and mark the correct option.
- $$2A + 2B \rightarrow 2AOH + H_2$$
- $$S + O_2 \rightarrow C$$
- $$C + B \rightarrow D$$
- | | A | B | C | D |
|-----|----|------------------|-----------------|--------------------------------|
| (1) | Na | H ₂ O | SO ₂ | H ₂ SO ₃ |
| (2) | Na | H ₂ O | SO ₂ | H ₂ SO ₄ |
| (3) | K | H ₂ O | SO ₂ | H ₂ SO ₄ |
| (4) | K | H ₂ O | SO ₃ | H ₂ SO ₃ |
42. When the vapour pressure of a liquid is equal to its atmospheric pressure, then it
- (1) freezes (2) evaporates
 (3) boils (4) does not undergo any change

43. Simple distillation can be best used to separate
- (1) A mixture of benzene (boiling point 80°C) and toluene (boiling point 100°C)
 - (2) A mixture of ether (boiling point 35°C) and toluene (boiling point 110°C)
 - (3) A mixture of ethanol (boiling point 78°C) and water (boiling point 100°C)
 - (4) None of these
44. Take a mixture of powdered iron and copper oxide. Heat the mixture. The mixture starts glowing with a shining brown colour and it glows even after the burner is removed. Iron oxide and copper are formed during the reaction. It is observed that iron takes away oxygen from copper and acts as a reducing agent. What general observation can be made from the above experiment ?

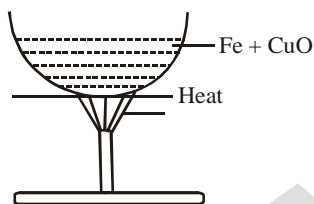

- (1) When a metal is heated with the oxide of a more reactive metal it will act as a reducing agent
- (2) A more reactive metal can displace the less reactive metal from its oxide on heating
- (3) The reaction of more reactive metal with an oxide of less reactive metal is endothermic
- (4) No general statement can be given

45.

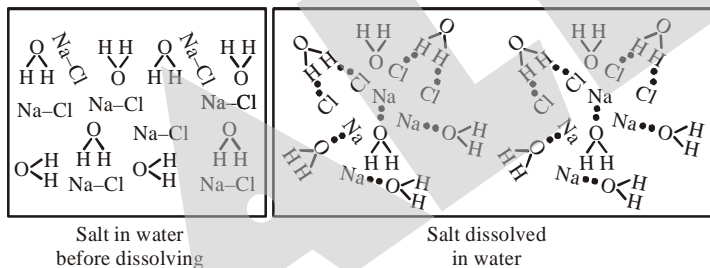

According to the diagram, which statement best describes what happens to ionic compounds when they are dissolved ?

- (1) They are pulled apart by water molecules
- (2) They get larger in size
- (3) They move faster
- (4) They become a new compound

Comprehension for (Q.No. 46 to Q.No.48)

Atoms of same element containing same number of protons but different atomic masses are known as isotopes whereas atoms of different elements having same atomic mass but different atomic numbers are known as isobars. Isotopes have same chemical but different physical properties whereas isobars have different chemical properties.

46. Which of the following pairs are isotopes:
- (1) Oxygen and Ozone (2) Ice and steam
(3) Nitric oxide and nitrogen di oxide (4) Hydrogen and deuterium
47. An isotope of sodium finds application in
- (1) Detection of blood clot (2) Fuel in nuclear reactions
(3) Survey of archaeological samples (4) None of these
48. Metal oxides are
- (1) Acidic (2) Basic (3) Neutral (4) None

Comprehension for (Q.No.49 & Q.No.50)

An emulsion is a system in which the dispersion medium and the dispersed phase both are liquids. The liquids must be immiscible.

Emulsions are classified into two types.

- (i) Oil in water emulsion
(ii) Water in oil emulsion

A stable emulsion usually requires an emulsifying agent, which forms film in the oil-water interface and thus prevents coalescence of the droplets.

49. The example of oil in water emulsion is
- (1) Milk (2) opal
(3) cod-liver oil (4) None of these
50. The emulsifying agent generally used is/are
- (1) soap (2) gelatin
(3) both soap and gelatin (4) soap, gelatin and other hydrophilic sols.

SECTION-C : BIOLOGY

This section contains **15 Multiple Choice Questions**. Each question has four choices (1), (2), (3) and (4) out of which **ONLY ONE** is correct.

51. Identify the following organism and state to which phylum it belongs ?



- (1) Coelenterata (2) Porifera (3) Platyhelminthes (4) Annelida

52. Which of the following is causative agent of peptic ulcer ?
 (1) *Helicobacter pylori* (2) *Leishmania*
 (3) *Trypanosoma* (4) Roundworm
53. Which of the following muscle is responsible for movement of food in alimentary canal ?
 (1) Smooth Muscle (2) Striated Muscle (3) Voluntary Muscle (4) Cardiac Muscle
54. Which of these is not related to endoplasmic reticulum ?
 (1) It helps in the exchange of materials between nucleus and cytoplasm.
 (2) It transports material between various regions in cytoplasm.
 (3) It is the site of energy generation.
 (4) It is the site for some biochemical activities of the cell.
55. Woody female cones, like the one shown below, and male cones grow on the same tree. In which division of seeded plants would they be found?



- (1) *Cycas* (2) *Pinus* (3) Fern (4) *Ginkgo*
56. The process of cross breeding between two different varieties of crop plants each having a desired characteristic is known as
 (1) Selection (2) Hybridisation (3) Emasculation (4) Introduction
57. What can a grower do to produce plants that are attractive and full of side branches?
 (1) Pinch off the apical meristem to decrease the amount of auxin.
 (2) Pinch off the apical meristem to increase the amount of auxin.
 (3) Pinch off the intercalary meristems to increase the amount of auxin.
 (4) Pinch off the intercalary meristems to decrease the amount of auxin.
58. Crossing over that results in genetic recombination in higher organisms occurs between
 (1) Non sister chromatids of a bivalent (2) Two daughter nuclei
 (3) Two different bivalent (4) Sister chromatids of a bivalent
59. *Peripatus* is a connecting link between
 (1) Coelenterata and Porifera (2) Ctenophora and Platyhelminthes
 (3) Mollusca and Echinodermata (4) Annelida and Arthropoda
60. What type of tissue is located at the area labelled D in the diagram below ?

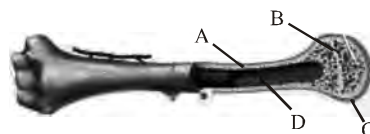

- (1) Compact bone (2) Spongy bone
 (3) Bone marrow (4) Cartilage

67. If $A : B = 2 : 3$, $B : C = 4 : 5$, and $C : D = 6 : 7$ then $A : B : C : D$ is
 (1) $16 : 22 : 30 : 35$ (2) $16 : 24 : 15 : 35$ (3) $16 : 24 : 30 : 35$ (4) $18 : 24 : 30 : 35$
68. A car travels the first $\frac{1}{3}$ of a certain distance with a speed of 10 km/h, the next one third distance with a speed of 20 km/h and last $\frac{1}{3}$ distance with a speed of 60 km/h. The average speed of the car for the whole journey is
 (1) 18 km/h (2) 24 km/h (3) 30 km/h (4) 36 km/h
69. Evaluate the perimeter of the figure given below to one decimal place.

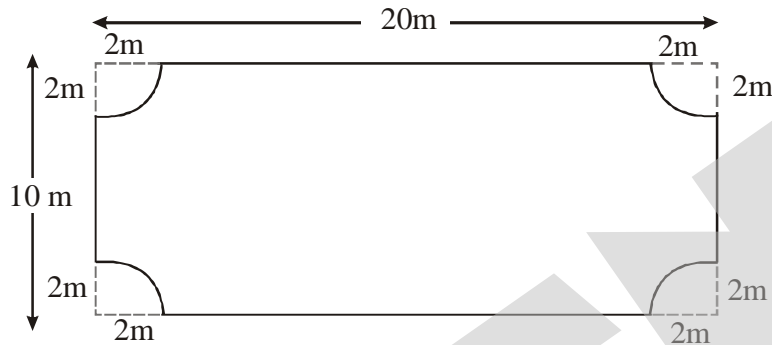

- (1) 56.0 m (2) 56.6 m (3) 57.2 m (4) 57.9 m
70. In the figure, given below find $\angle Z$.

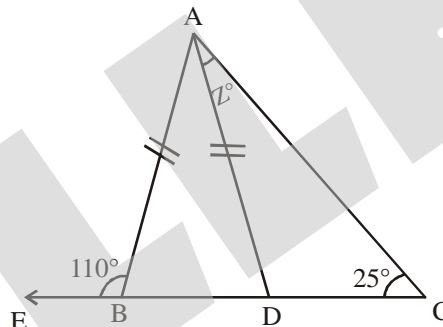

- (1) 40° (2) 110° (3) 45° (4) None
71. The rates of simple interest in two banks A and B are in the ratio 5:4. A person wants to deposit his total savings in two banks in such a way that he received equal half yearly interest from both. He should deposit the saving in banks A and B in the ratio
 (1) 5:2 (2) 2:5 (3) 4:5 (4) 5:4
72. If $|x + 3| = 2$ and $|y + 8| = 3$ then find least value of $|xy|$
 (1) 5 (2) -5 (3) 7 (4) 8
73. In the adjoining figure, $\angle 1 + \angle 2 + \dots + \angle 12$ equals

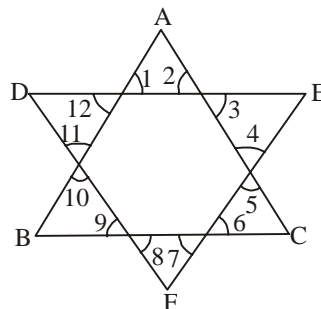

- (1) 180° (2) 540° (3) 720° (4) None of these

74. If the perimeter of an isosceles right triangle is $2P$, then its area is

- (1) $(2 + \sqrt{2})P^2$ (2) $(2 - \sqrt{2})P^2$ (3) $\frac{(3 - 2\sqrt{2})P^2}{4}$ (4) $(3 - 2\sqrt{2})P^2$

75. A rail engine is moving at a uniform speed of 30 km per hour towards a place "X". When the engine is still 20 km away from "X", an insect starts at "X" and shuttles between "X" and engine at a uniform speed of 42 km per hour. The total distance travelled by the insect, by the time engine reaches "X" is

- (1) 28 km (2) 30 km (3) 20 km (4) 42 km

76. The value of

$$\frac{1}{1+\sqrt{2}} + \frac{1}{\sqrt{2}+\sqrt{3}} + \frac{1}{\sqrt{3}+\sqrt{4}} + \frac{1}{\sqrt{4}+\sqrt{5}} + \frac{1}{\sqrt{5}+\sqrt{6}} + \frac{1}{\sqrt{6}+\sqrt{7}} + \frac{1}{\sqrt{7}+\sqrt{8}} + \frac{1}{\sqrt{8}+\sqrt{9}}$$
 is

- (1) 0 (2) 1 (3) 2 (4) 4

Comprehension for (Q.No.77 & Q.No.78)

The linear equation that converts Fahrenheit ($^{\circ}\text{F}$) to Celsius ($^{\circ}\text{C}$) is given by the relation

$$C = \frac{5F - 160}{9}$$

77. If the temperature is 35°C , temperature in Fahrenheit is :

- (1) 95°F (2) 96°F (3) 98°F (4) 94°F

78. What is the numerical value of the temperature which is same in both the scales ?

- (1) 40 (2) -40 (3) 50 (4) -50

Comprehension for (Q.No.79 & Q.No.80)

In figure, lines XY and MN intersect at O. If $\angle\text{POY} = 90^{\circ}$ and $a : b = 2 : 3$, then

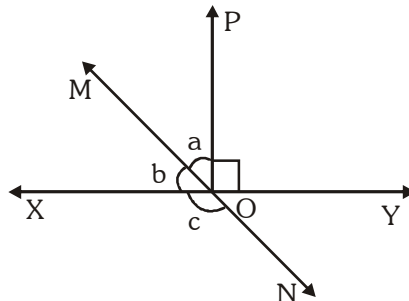

79. Measure of angle 'a' is

- (1) 54° (2) 36° (3) 126° (4) None of these

80. Measure of angle 'c' is :

- (1) 126° (2) 36° (3) 54° (4) None of these

ANSWER KEY

Que.	1	2	3	4	5	6	7	8	9	10	11	12	13	14	15	16	17	18	19	20
Ans.	1	4	2	4	2	1	1	2	4	4	4	3	1	3	1	2	2	1	1	3
Que.	21	22	23	24	25	26	27	28	29	30	31	32	33	34	35	36	37	38	39	40
Ans.	3	4	2	2	4	2	1	1	4	4	4	2	3	2	2	3	1	1	1	3
Que.	41	42	43	44	45	46	47	48	49	50	51	52	53	54	55	56	57	58	59	60
Ans.	1	3	2	2	1	4	1	2	1	4	1	1	1	3	2	2	1	1	4	3
Que.	61	62	63	64	65	66	67	68	69	70	71	72	73	74	75	76	77	78	79	80
Ans.	3	2	3	2	1	2	3	1	2	3	3	1	3	4	1	2	1	2	2	1